

adaptmyhome.CO.UK



ONYX  
CARE POD

# Onyx Care Pod

During these unprecedented times, reducing exposure to Covid-19 by limiting contact between contractors and clients is imperative.

Developed alongside local authorities, housing associations, occupational therapists and contractors, our new Onyx Care Pod is a stylish yet functional standalone cubicle.

Cubicle installation is possible within two hours where water, waste and power are provided, allowing for a full adaptation to be completed within two days, vastly reducing inconvenience and fulfilling the needs of the end user much faster.



# Product advantages



Safe and accessible with fully recessed or low-level entry

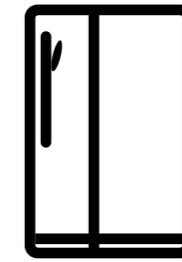

Standalone cubicle

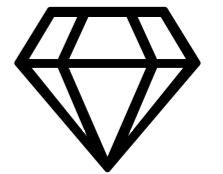

Contemporary design

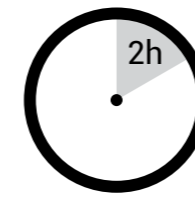

Quick and easy installation

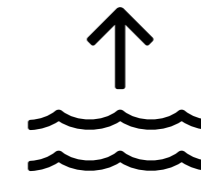

100% waterproof  
Exclusions apply to door area.

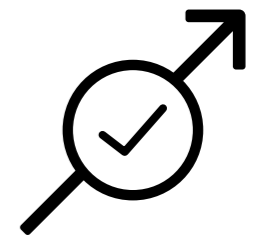

Future-proofed solution

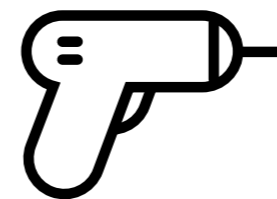

Supports a number of mobility aids and accessories

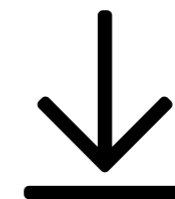

Slip-resistant, textured slate finish shower tray. Can be recessed for wheelchair access.



Lifetime guarantee  
Exclusions apply see page 14

# Onyx Care Pod



Onyx Care Pod installation with 9.5kw SmartCare Plus BEAB Care approved electric shower.



Onyx Care Pod installation with Arka thermostatic care mixer valve (TMV3).

# Alternative adaptation solutions



AKW Standalone Showerloo cubicle.



Level-access shower.

# OT benefits

## Falls risk reduction

- + The Onyx shower tray is our shallowest yet at only 26mm which significantly reduces the threshold for an ambulant user.
- + The Onyx shower tray boasts a higher slip-resistance rating than other surface mounted trays, whilst caring for the client's skin with a textured slate finish.
- + High-quality, AKW Larenco 6mm toughened glass is included for added user safety.

## Client-centred & holistic

- + The Onyx shower tray can be recessed to provide level entry or alternatively a ramp can be supplied.
- + Shower controls can be positioned for easy use to maximise independence.
- + Grab rails can be installed within the Onyx Care Pod to ensure LRV colour contrast for clients with visual impairment. The mid-grey grab rails from our dementia-friendly range also reinforce the importance of aesthetics for long-term health and well-being.
- + The wall panels are structural and allow shower seats and grab rails to be fixed directly either during or post installation at any user specific height.
- + Duolinx magnetic locking handle system allows the user or carer flexibility over opening/closing one or both screens, minimising moving and handling manoeuvres and maximising dignity.

## DFG suitable

- + Extremely competitive pricing makes DFG a realistic funding option for the Onyx Care Pod.
- + Vastly reduced installation time – maximum two days, compared to traditional 5-7-day adaptation. This reduces labour costs as well as costs associated with respite or alternative accommodation whilst works take place.
- + The lifetime guarantee enables budget holders to approve installation with confidence.
- + Future-proofed solution - the recessed Onyx shower tray provides level access, the care accessories used meet the required LRV for visual impairment, and the duo doors allow carer-assisted bathing, providing a long-term solution which considers the user's future requirements.

## Infection control

- + Wall panels harbour less bacteria than grouted tiles. They lower maintenance for the client or their carers, enabling them more time and energy to engage in meaningful activities.
- + Wall panels are a great solution for clients with smearing tendencies.
- + Reduced installation time minimises client and contractor contact with associated virus and infection risk reduction.

# End user benefits

- + We understand the anxiety about **falls** and the Onyx Care Pod is designed to **reduce this risk** so that the client can remain confident (or indeed regain confidence) and **engage in meaningful activity**.
- + The Onyx shower tray is our shallowest yet, only 26mm, meaning a lower threshold and **reduced tripping hazards**.
- + **Grab rails and seats** can be installed at any time, directly to the structural wall panels at a position and height that suits you.
- + Toughened glass offers **increased safety** without compromising on visibility or aesthetics.

- + **It looks great!** We understand that adaptations should be in keeping with the home and do not need to reinforce perceived disability. An adaptation that does not look nice can have a long-term impact on health and well-being, so we have made sure the Onyx Care Pod looks good whilst facilitating safety and independence.
- + The lifetime guarantee gives you absolute **peace of mind**.
- + **Quick installation** means less upheaval and stress, as well as reducing infection risks.
- + **Easy to clean** with warm soapy water.
- + Care accessories **reduce risks** whilst maximising your independence and dignity.



# Specifier and contractor benefits

- + Vastly reduced installation time – maximum of two days to remove the existing bathroom and install the Onyx Care Pod, when compared with the traditional 5-7 day adaptation installation – which decreases labour, time and costs, as well as contact with, and inconvenience for residents.
- + Reduced installation time also means the same team of installers could complete 2-3 installations a week. This would help to clear any backlogs, allow quicker spend of DFG budgets and should be more profitable for the installer.
- + When factoring in the initial material costs against labour and time savings, we expect the total cost of supply and fit should be in line with a standard adaptation while using much higher end products.
- + Less preparation is required, e.g. no need to strip, prepare and tile existing walls. Any patching work needed will be minimal compared to completing a full adaptation.
- + Less decorative work is also required, as ceilings etc. are far less likely to have been damaged during the removal stage.
- + Fewer materials are required on site and all supplies, including timber and plumbing fittings, can be sent in one contact-free delivery from AKW.
- + Compatible with gravity and pumped waste options offering greater installation flexibility. Pumped waste option is 53mm below the shower tray level so should be within the screed for use with unbreachable floors.
- + Simplified costing for materials with the Onyx Care Pod pricing method and AKW One service offering.
- + Care Pod base structure comes attached to the Onyx shower tray, reducing installation time, leaving less room for error and enabling a watertight finish.
- + No specialist floor coving is required, which would be typically used in a wet room adaptation. This allows the flooring to be potentially done in-house rather than subcontracted.
- + The simple and effective installation method reduces the chance of snagging and call backs to site.



Onyx Care Pod with duo door for carer-assisted bathing.

# Dimensions

Alcove Duo  
1200x800

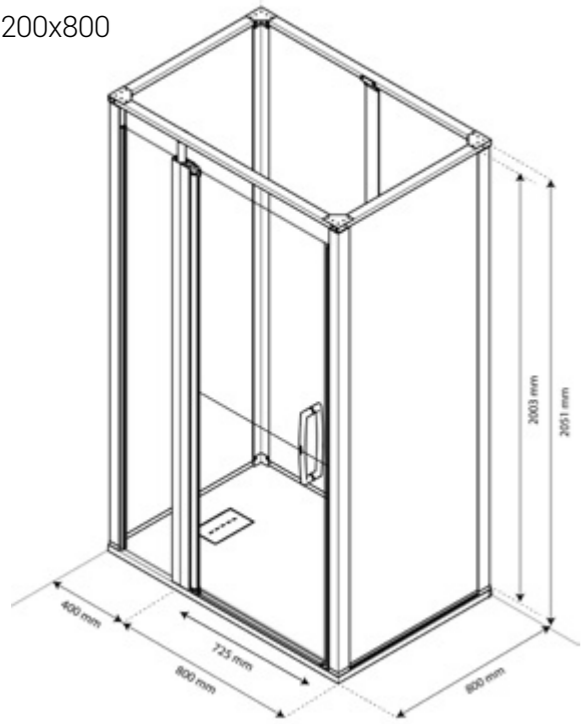

Alcove Duo  
1200x900

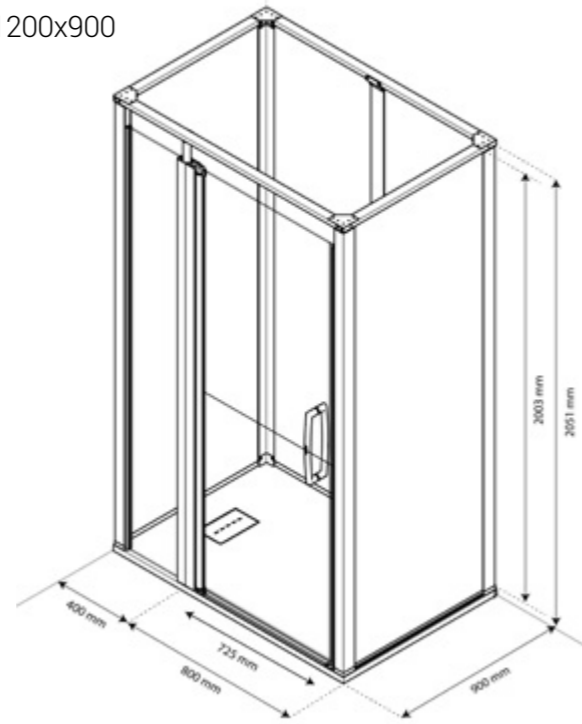

Alcove Duo  
1600x800

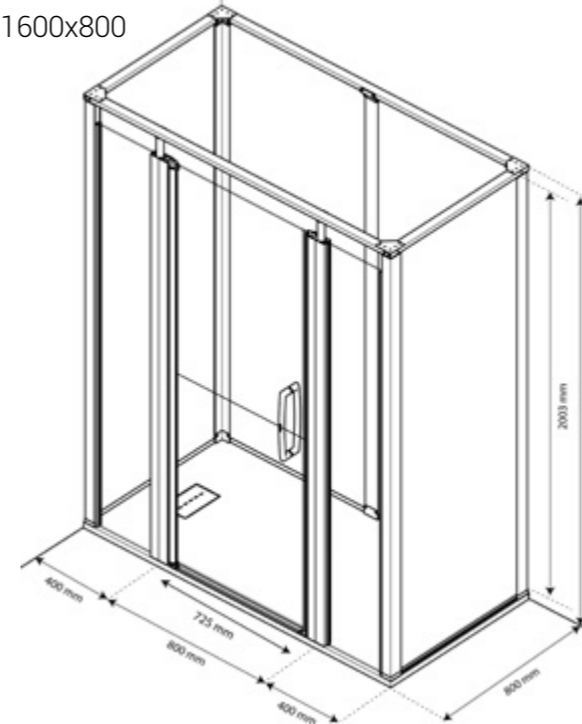

Alcove Duo  
1600x900

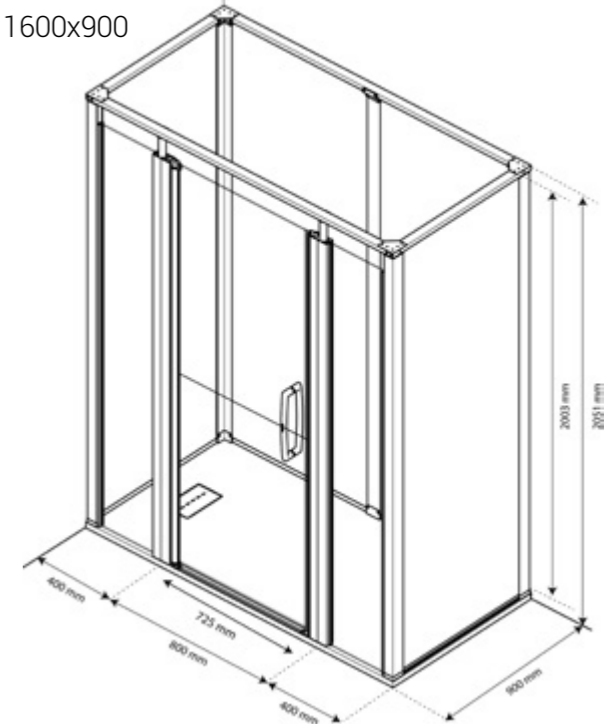

Alcove Duo  
1400x800

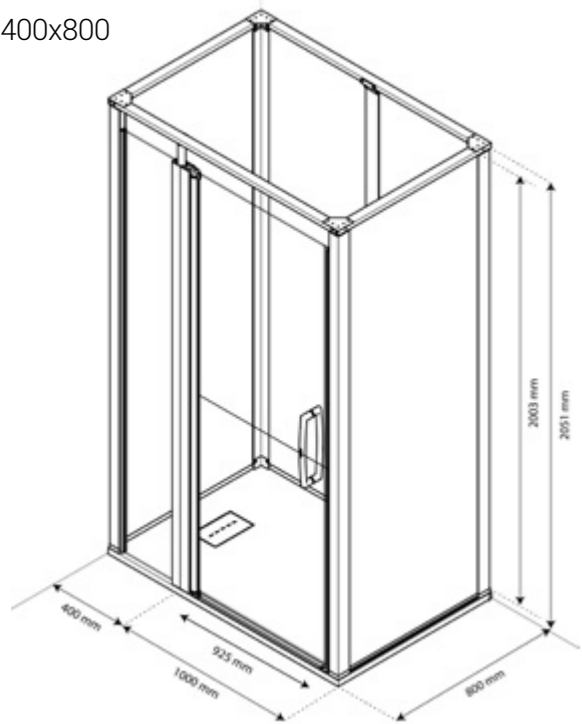

Alcove Duo  
1400x900

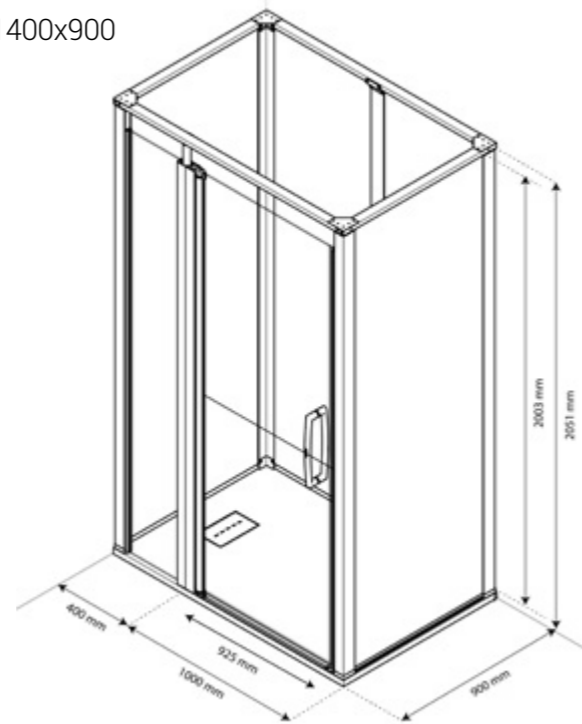

Alcove Duo  
1700x800

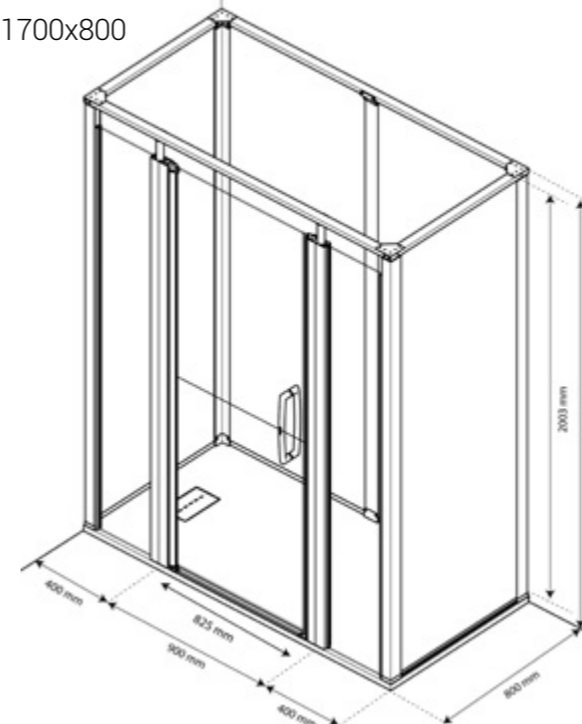

Alcove Duo  
1700x900

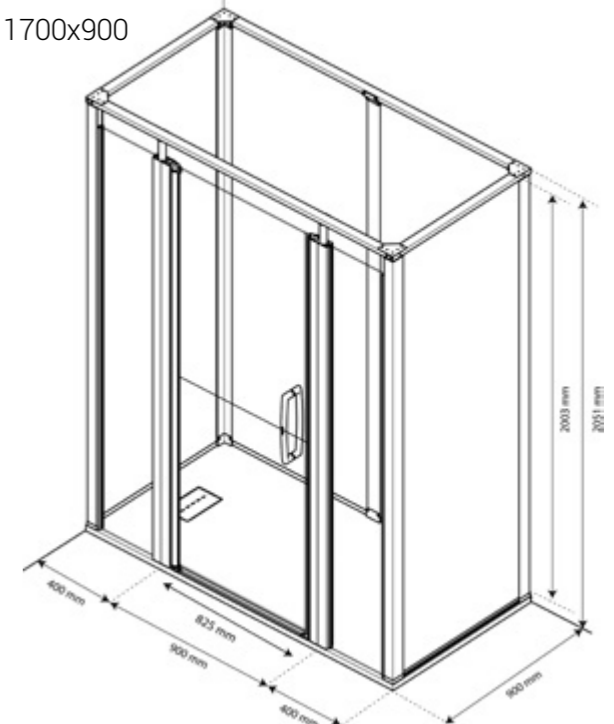

# Dimensions

Corner Duo  
1200x800

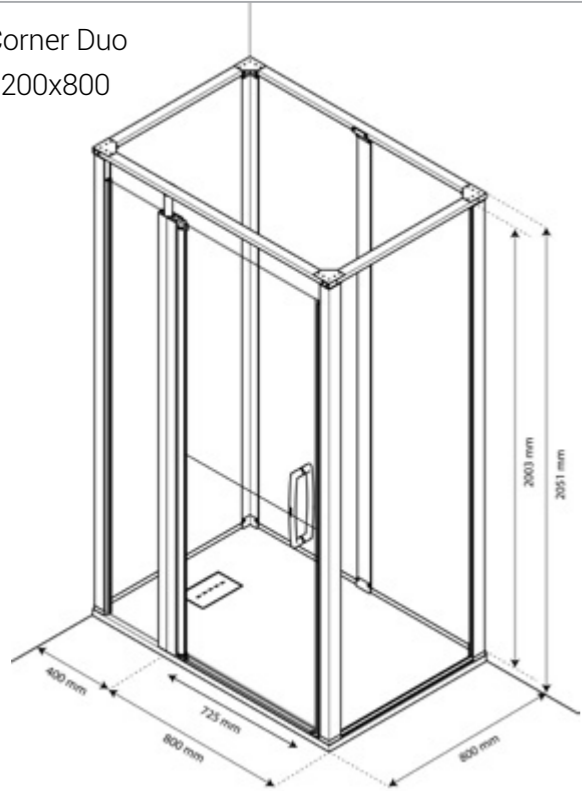

Corner Duo  
1200x900

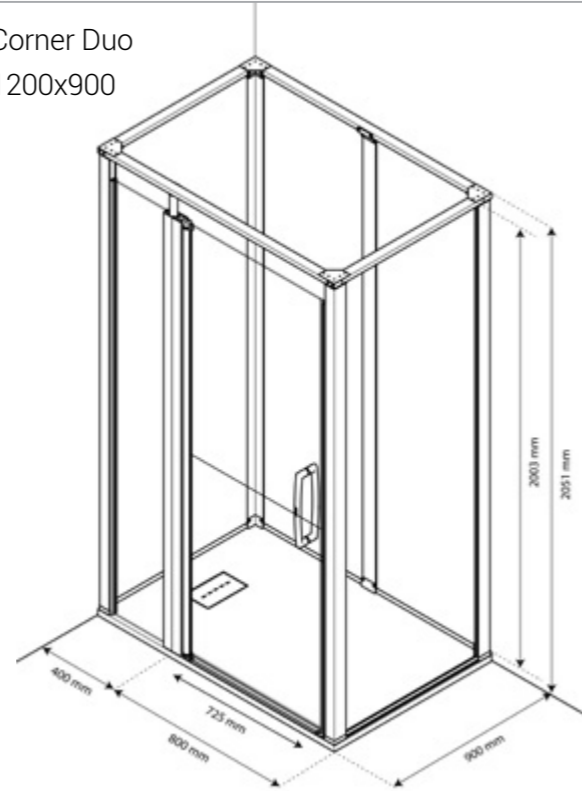

Corner Duo  
1600x800

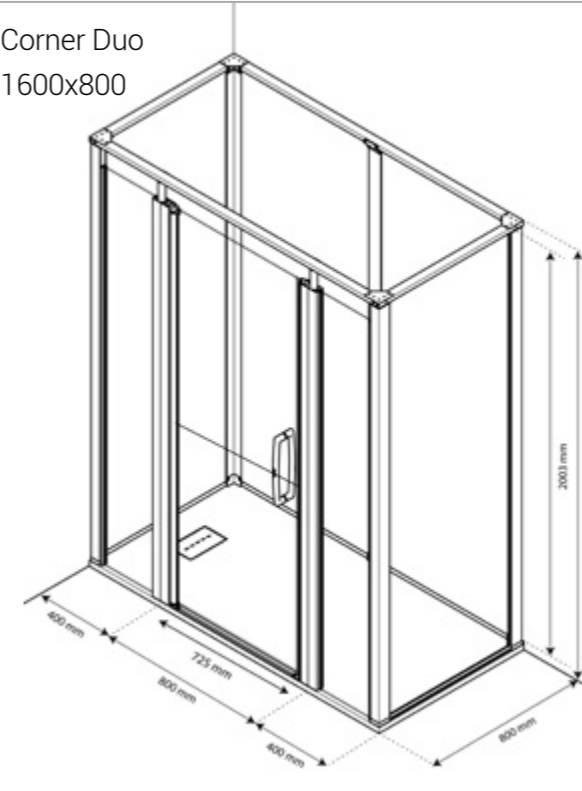

Corner Duo  
1600x900

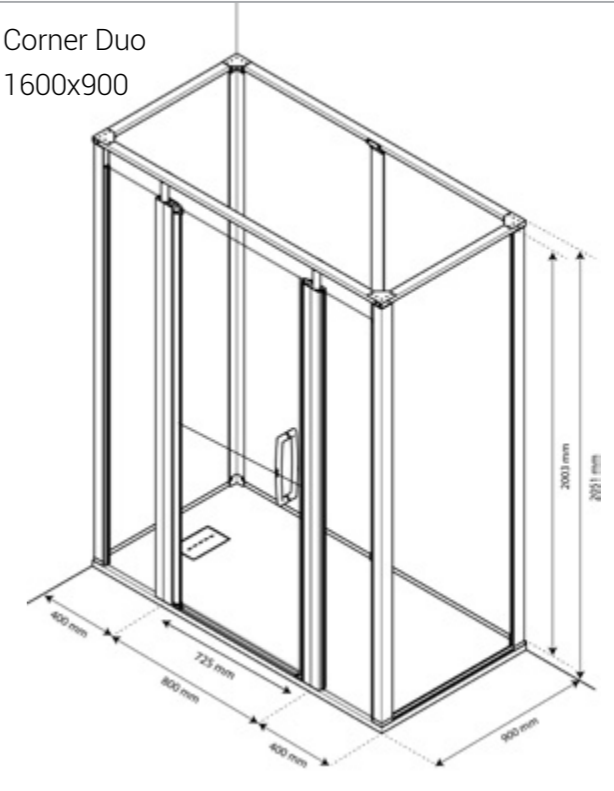

Corner Duo  
1400x800

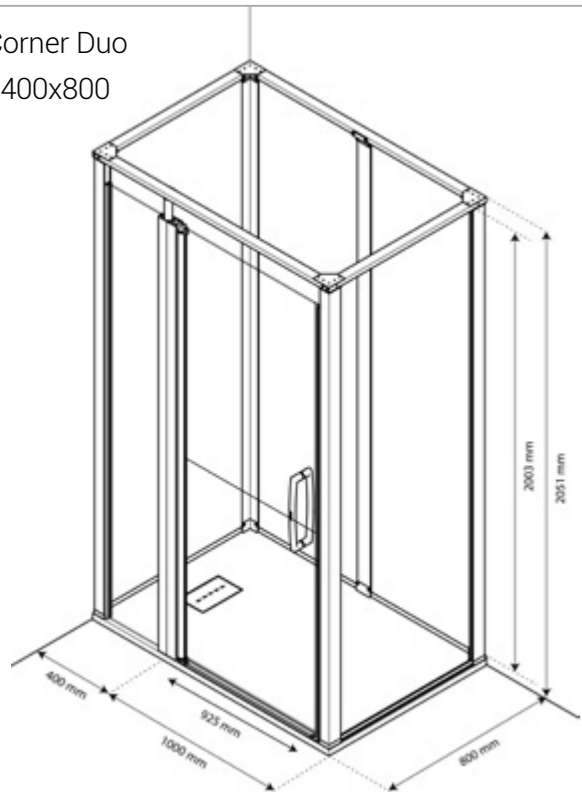

Corner Duo  
1400x900

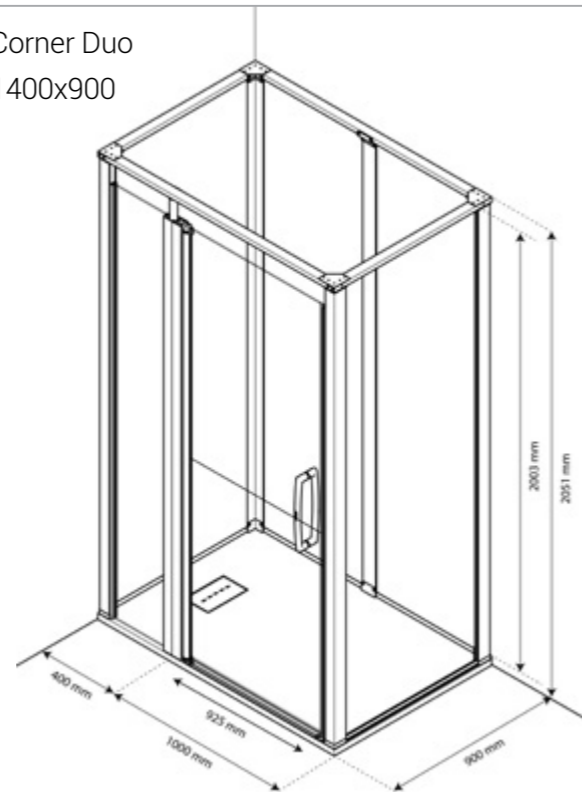

Corner Duo  
1700x800

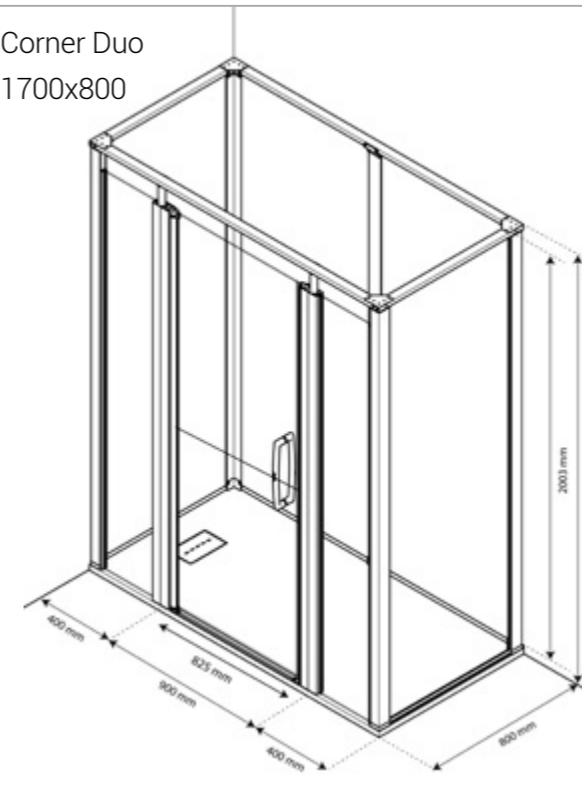

Corner Duo  
1700x900

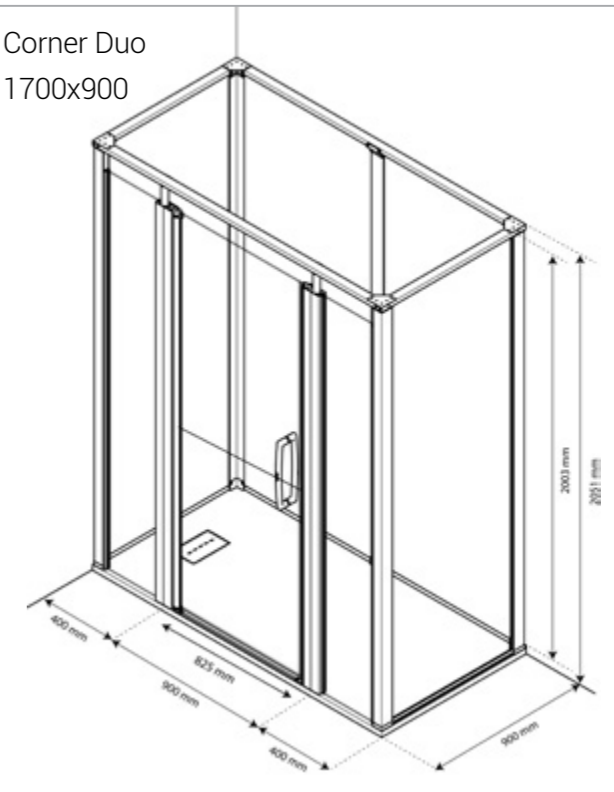

## YOUR ORDER – PRICING GUIDE

There are significant cost savings due to the time saved with the installation method for this product, which give you access to much higher end products for the approximate cost of a standard adaptation. Pricing below is for all materials required; please request a supply and fit price from your installer.

Working closely with our contacts in the market has highlighted the importance of making this exciting product with its various options easy to specify. With the Onyx Care Pod configurator, we have simplified the costing of hundreds of possible configurations, making it easy for the OT, specifier or contractor to specify the right solution for their client.

**£2100 for gravity Care Pod and accessories (no sanitaryware).** This relates to the following selections and options:

<b>1</b>	A – D	<b>5</b>	A
<b>2</b>	A – B	<b>6</b>	A – B
<b>3</b>	A – B	<b>7</b>	C
<b>4</b>	A – B	<b>8</b>	A

**£2400 for pumped Care Pod and accessories (no sanitaryware).** This relates to the following selections and options:

<b>1</b>	A – D	<b>5</b>	B
<b>2</b>	A – B	<b>6</b>	A – B
<b>3</b>	A – B	<b>7</b>	C
<b>4</b>	A – B	<b>8</b>	A

**£2200 for gravity Care Pod and accessories inc. sanitaryware.** This relates to the following selections and options:

<b>1</b>	A – D	<b>5</b>	A
<b>2</b>	A – B	<b>6</b>	A – B
<b>3</b>	A – B	<b>7</b>	A – B
<b>4</b>	A – B	<b>8</b>	A

**£2500 for pumped Care Pod and accessories inc. sanitaryware.** This relates to the following selections and options:

<b>1</b>	A – D	<b>5</b>	B
<b>2</b>	A – B	<b>6</b>	A – B
<b>3</b>	A – B	<b>7</b>	A – B
<b>4</b>	A – B	<b>8</b>	A

\*Prices could be subject to company price increase



The Onyx Care Pod and all AKW shower trays, AKW shower screens and AKW shower seats come with a lifetime warranty against manufacturing defects\*.

\*The lifetime warranty excludes normal wear and tear in general domestic applications. It applies only to products being installed for the first time and according to relevant local and national regulations.



As standard

AKW SmartCare Plus Electric Shower comes with a 5 year warranty as standard with extended warranties available\*.

\*Please note that the product must be registered within 30 days with AKW Medi-Care Limited to activate your guarantee.



AKW electrical items come with a 5-year warranty against manufacturing defects\*.

Other branded electrical products carry the warranty of the manufacturer. \*Excluding extractor fans which carry 3 year warranty.



As standard

AKW Arka® Thermostatic Mixer Shower comes with a 3 year warranty as standard with extended warranties available\*.

Please refer to our terms and conditions in the AKW catalogue for further information. \*2 year extended warranty option available.

## YOUR ORDER – ONYX CARE POD CONFIGURATOR

To create your unique Onyx Care Pod, choose one option from selection 1 – 8. Tick your options in reference to the pricing guide and then add to the selection summary. You can then order the required Care Pod by sending a copy of this configurator to [hello@adaptmyhome.co.uk](mailto:hello@adaptmyhome.co.uk) or by calling **02920 611 277** and providing your selected options.

Option	Selection 1 – Length	Tick
A	1200mm	
B	1400mm	
C	1600mm	
D	1700mm	
Option	Selection 2 – Width	Tick
A	800mm	
B	900mm	
Option	Selection 3 – Handing (external view)	Tick
A	Right hand (waste on the right)	
B	Left hand (waste on the left)	
Option	Selection 4 – Enclosure type	Tick
A	Alcove	
B	Corner	
Option	Selection 5 – Waste options	Tick
A	Gravity waste	
B	Pumped waste with pump	
Option	Selection 6 – Shower options	Tick
A	Arka thermostatic care mixer valve (TMV3)	
B	9.5kw SmartCare Plus BEAB Care approved electric shower	
Option	Selection 7 – Sanitaryware options	Tick
A	Raised height close coupled toilet pan pack with mid-grey seat & 450mm basin & monoblock lever spray mixer tap	
B	Standard height close coupled toilet pan pack with mid-grey seat & 450mm Basin & monoblock lever spray mixer tap	
C	No sanitaryware required	
Option	Selection 8 – Additional care products that come as a standard with all Care Pods	Tick
A	Mid-grey steel grab rail (450mm) x 2	✓
	2000 series mid-grey, fold-up padded shower seat with height adjustable leg kit	
	Moisture-resistant LED light - 18W	

SELECTION SUMMARY	
Selection	Option
1	
2	
3	
4	
5	
6	
7	
8	A

Notes





**adaptmyhome**.CO.UK

Life Made Better

t: 02920 611 277

e: [hello@adaptmyhome.co.uk](mailto:hello@adaptmyhome.co.uk)

**Adaptmyhome**

160 Heol Llansihen Fach,  
Cardiff,  
CF14 6RG

[www.adaptmyhome.co.uk](http://www.adaptmyhome.co.uk)

