



# Harmony FE

## Homelift

[adaptmyhome.co.uk](http://adaptmyhome.co.uk)

Approved Terry Lift installers  
Specialists in Mobility lifts

Terry Lifts - A British manufacturer

[www.adaptmyhome.co.uk](http://www.adaptmyhome.co.uk)

Call 029 20 611 277 for free and impartial advice





## Why choose Terry Lifts?

### **The Harmony FE (Fully Enclosed) Home Lift makes your life easier when stairs become too much.**

Why go through the stress and upheaval of moving house? A Terry Lifts 'through the floor' Home Lift allows you to regain the freedom of your home, while keeping your staircase clear. It moves between floors smoothly and quietly, allowing you to travel safely and comfortably.

This 'through the floor' Home Lift requires much less space than a conventional lift. There is no shaft or

structure required and the footprint of the lift is so compact that it can be placed almost anywhere in your home.

### **We will take care of everything**

Purchasing and having your home lift installed is far less complicated than you might think.

We will survey your home and provide you with a written quotation. After your decision to proceed, we will first carry out all the necessary work. The installation itself takes less than two days.

# Comfortable and easy to use

## Why the Harmony FE makes life easy



Easy-to-use adjustable wireless controls come as standard in the cabin and at both floors.



A simple push of the button sends the lift up. The controls can be positioned to suit your needs.



The aperture ceiling panel is automatically lifted or replaced en-route.



The guides are set back against the wall and do not impact on the room.



Low cabin floor construction ensures easy wheelchair access and egress.



The lift can be sent to the floor which is unoccupied, leaving a feeling of space in the room.

# Features

## Standard features

- ✓ Powered door
- ✓ Door open button on the external side of the lift cabin
- ✓ Easy to use adjustable wireless cabin controls
- ✓ Gloss white exterior and interior trims
- ✓ Full height glazed door
- ✓ Glass vision side panels
- ✓ Light grey carpet covered interior panels
- ✓ Four dimmable LED lights
- ✓ Telephone
- ✓ Charcoal carpeted floor
- ✓ Wireless call stations on both landings
- ✓ Wireless smoke/heat alarm
- ✓ Emergency lowering system
- ✓ 325 kg (51 stone) capacity
- ✓ 1 year parts and labour warranty

## Cabin details

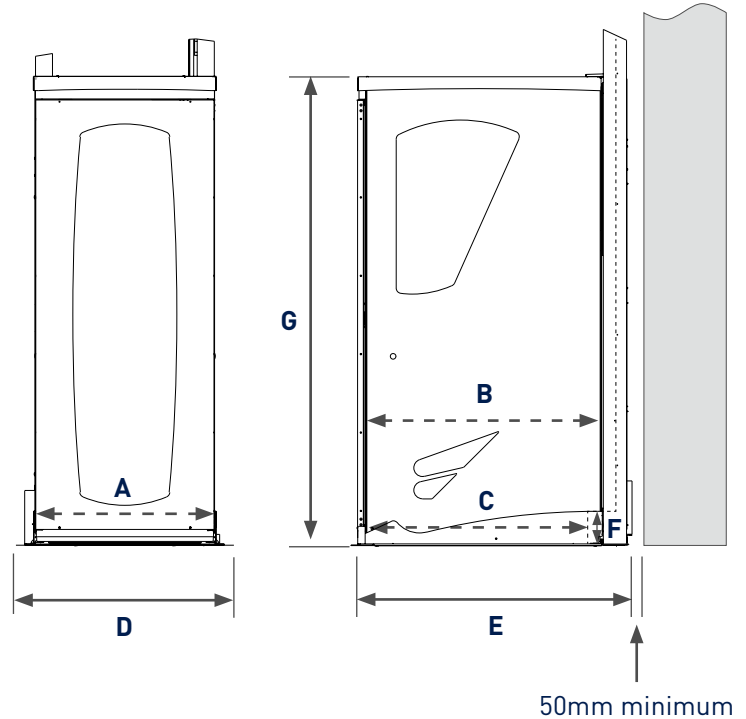

## Optional extras

- ✓ Upholstered fold up seat
- ✓ Joystick cabin control
- ✓ Hand-held remote control
- ✓ Radio isolation fob
- ✓ Handrail
- ✓ Grab points
- ✓ Mirror
- ✓ LED cabin side lighting
- ✓ Extended warranties including service visits

## Optional finishes

- ✓ Choice of carpet colour
- ✓ Cabin available in alternative RAL colours

Lift model	A Internal width	B Internal length above axle cover	C Internal length to axle cover	D External width	E External length	F Axle cover height	G Cabin height	Travel	Capacity
Harmony FE C (Compact)	745	826	726	910	914	90	2160	2400-3600	325 kg
Harmony FE S (Standard wheelchair)	745	1148	1045	910	1235	90	2160	2400-3600	325 kg
Harmony FE L (Wheelchair + attendant)	745	1348	1245	910	1435	90	2160	2400-3600	325 kg
Harmony FE LW (Wheelchair + attendant)	880	1348	1245	1045	1435	90	2160	2400-3600	325 kg



Toughened glass vision panels, as standard, give the car a solid feel compared to scratch-prone plastic alternatives

# Peace of mind

**At Terry Lifts, we have combined luxury with the latest technology, making our new Harmony FE a top of the range lift of the highest quality.**

- ✓ Members of LEIA (Lift and Escalator Industry Association) – means that we operate under a particular code of conduct which requires us to have all relevant technical and quality certification as well as guaranteeing the supply of spare parts for years to come

- ✓ Should a power outage occur at your property whilst the Harmony FE Lift is in use, the manual lowering system and battery backup will return you safely to the ground floor. The system can be operated from inside and outside the cabin, allowing lone occupants to use the lift in complete confidence
- ✓ A load capacity of 325kg (51 stone)
- ✓ 12 month warranty including one service visit
- ✓ We have a dedicated aftercare support team to assist you with using your lift

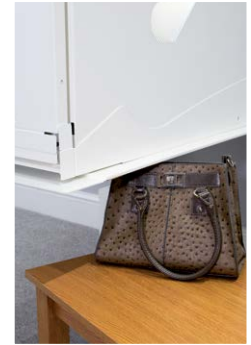

Pressure sensitive safety surfaces stop the lift if obstructed from above or below

## The Terry Promise



### Safety First

Your safety is our primary concern. It is important that you feel safe and secure when you are using your Harmony FE Lift.

- ✓ Pressure sensitive surfaces and safe edges
- ✓ Emergency lowering in case of power cuts and easy to use manual lowering
- ✓ 30-minute fire protection between the upper and lower floors, whether the lift is parked upstairs or downstairs, to the requirements of BS5900: 2012
- ✓ Smoke or heat alarms provided on both floors

### Ensuring we comply:

- ✓ Compliant with the Machinery Directive
- ✓ Independently certificated by a Notified Body as is our legal requirement
- ✓ Compliant with British Standards BS 5900:2012. Dedicated permanent electrical supply, as required by BS 5900
- ✓ The Harmony Homelift fully complies with the Chartered Institute of Building Services Engineers (CIBSE) Guide D recommendations



## Frequently asked questions

**Is it possible for the lift to stop between floors when I am on my own?** If there is a power cut at your property, then the battery backup will maintain operational control of the lift to lower to the ground floor. If all else fails, the manual lowering system can be operated with assistance from outside the lift to enable you to travel to the ground floor. In addition, we provide a telephone inside the lift which is Included with your lift package. The telephone will require a connection to your incoming telephone landline.

**Can I use my wheelchair in a Harmony FE?** Yes you can. We offer three wheelchair models, the standard, the longer and the longer/wider. We have models which can accommodate a wheelchair, someone standing or a combination of both. Our Sales consultant can assist to decide on which size is most suitable. Please refer to internal dimensions guide on page 4.

**Do Terry Lifts manage the building work?** Yes, we can complete all building work or alternatively, we can provide a Specification Guide to your builder. The choice is yours. Normally, no major structural work is required.

**How much space does a Harmony FE Lift require?** The four Harmony FE models are designed to minimise the external footprint and maximise the internal car space for every need. The Compact is the smallest. Please refer to the dimension guide on page 4.

**Will the Harmony FE affect the fire integrity of my home?** The Harmony FE lift is fire and smoke test certificated by an approved and accredited test laboratory and complies with BS5900:2012 in relation to through floor lifts. This covers fire safety for the Harmony FE Lift in both the lower and upper position.

**I plan to keep my lift for a very long time, will Terry Lifts service and care for my lift?** Yes. Terry Lifts can provide a service and maintenance package to suit your requirements. Please contact our aftercare service team to discuss options that are available.

**Can installing a Harmony FE Lift be cheaper than moving home?** Yes, almost certainly. We are often told by our clients that it was cheaper and less stressful than moving home.



Harmony FE Home Lift

If you haven't previously considered a home lift, speak directly to the manufacturer and join the many customers who are experiencing the convenience and reliability of a Terry Lift. Call **01565 752 800** to ask any question, or to arrange a consultation.



Lifestyle Home Lift



Harmony Home Lift

**adaptmyhome** **.CO.UK**

**adaptmyhome**

160 Heol Llanishen Fach,  
Cardiff, CF14 6RG

Tel: 029 20 611 277

email: [hello@adaptmyhome.co.uk](mailto:hello@adaptmyhome.co.uk)

[www.adaptmyhome.co.uk](http://www.adaptmyhome.co.uk)



Proudly Designed and  
Manufactured in Britain